

Microscope connectivity panel

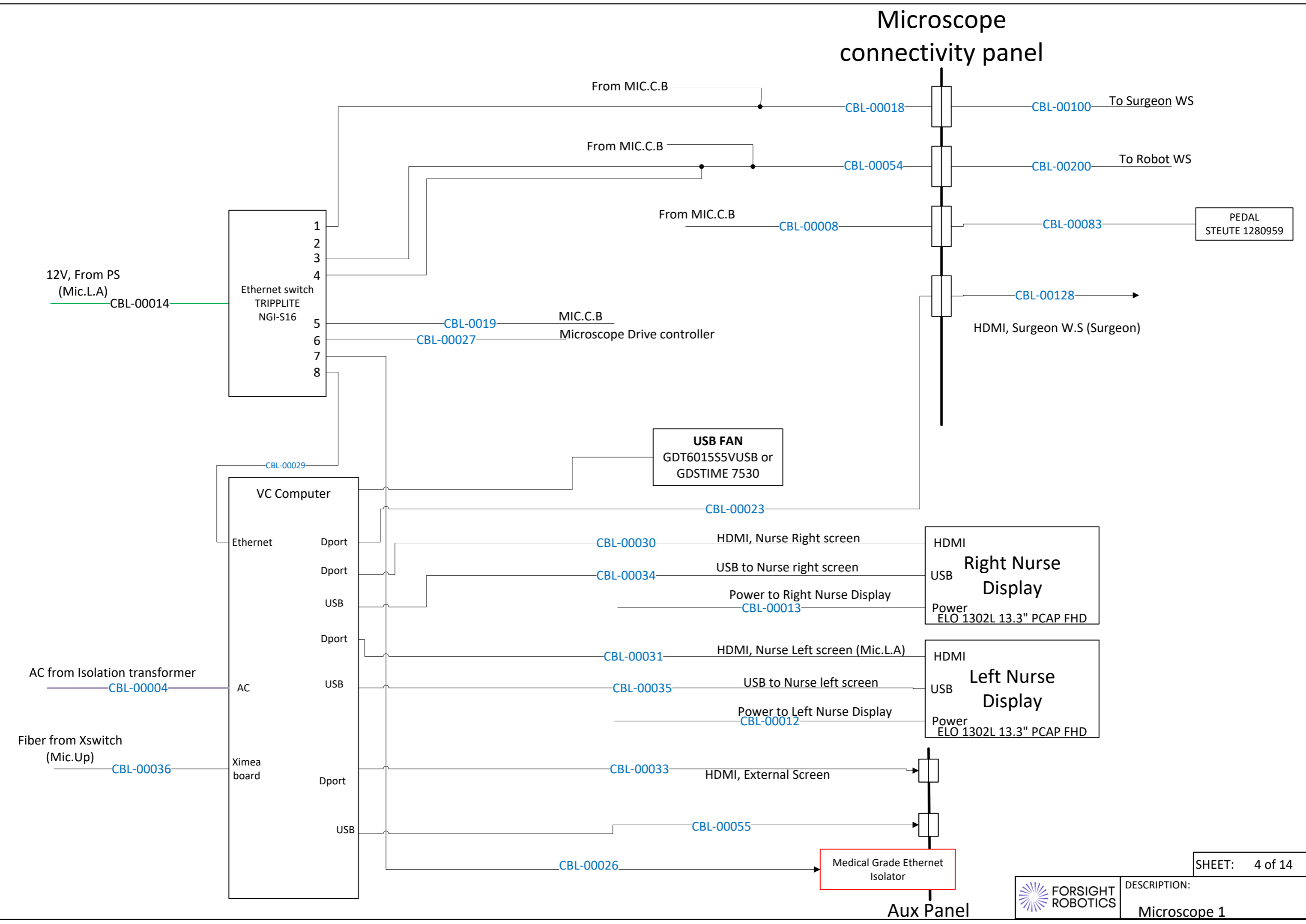

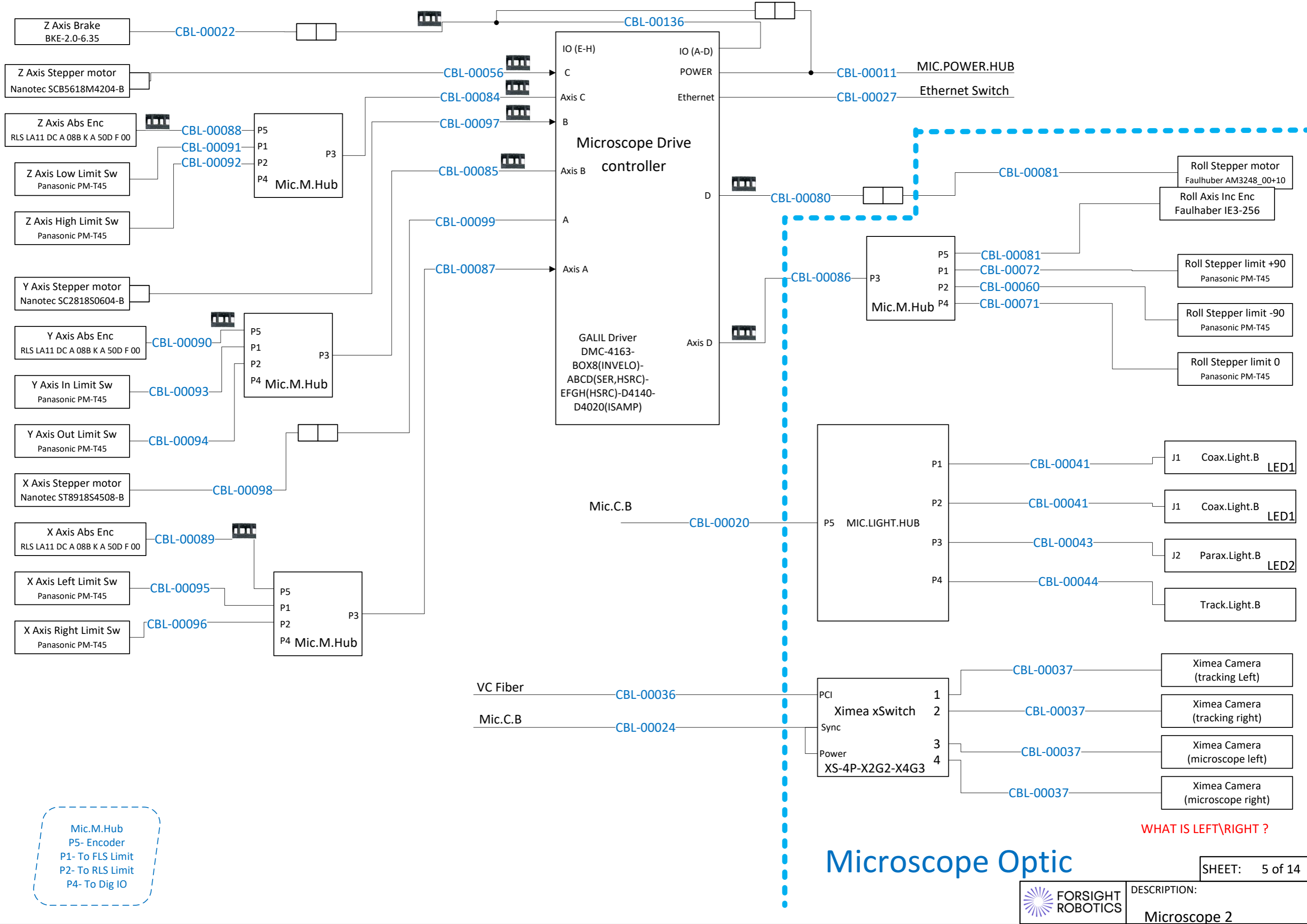

Mic.M.Hub
P5- Encoder
P1- To FLS Limit
P2- To RLS Limit
P4- To Dig IO

WHAT IS LEFT\RIGHT ?

Microscope Optic



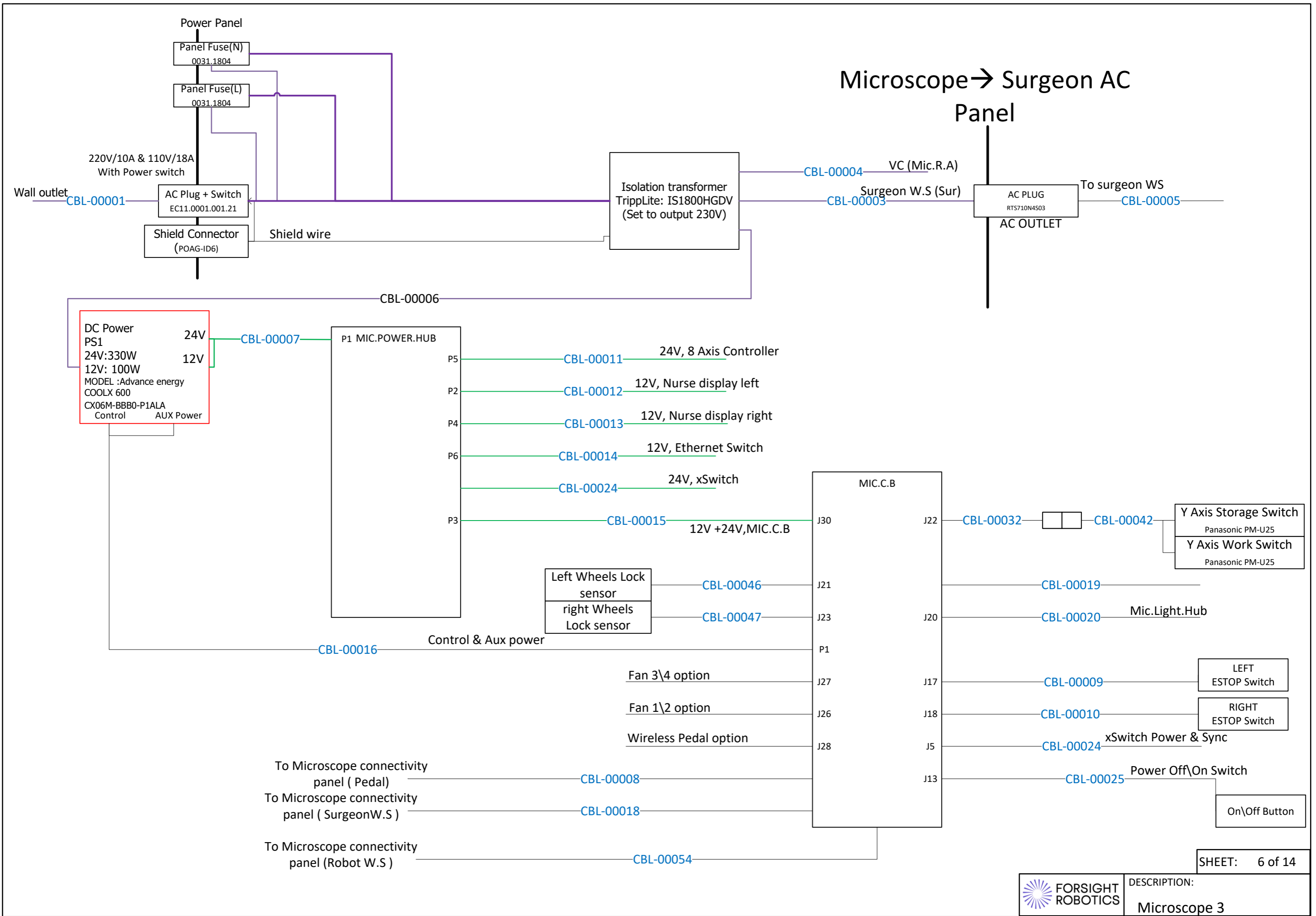

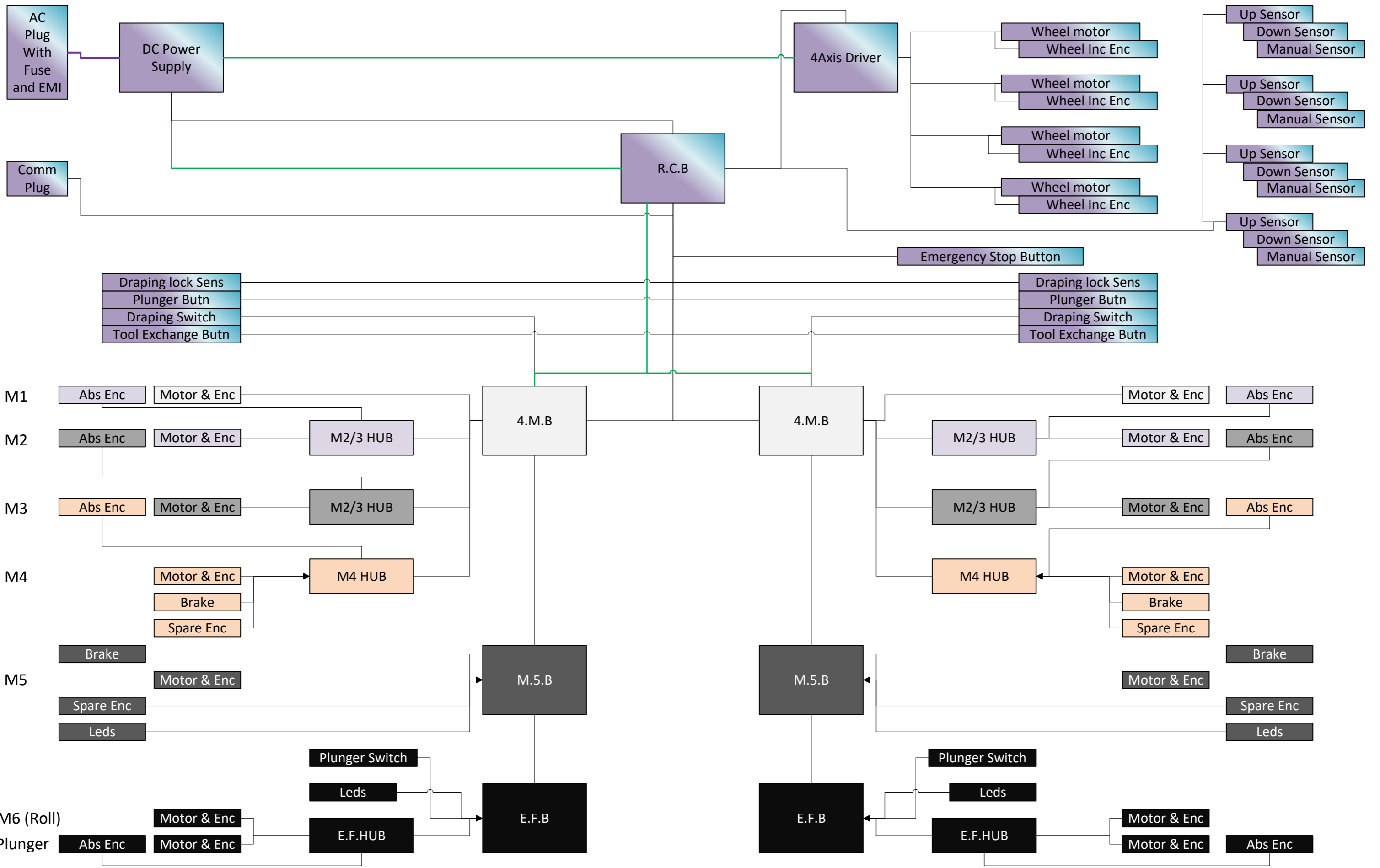

Color codes



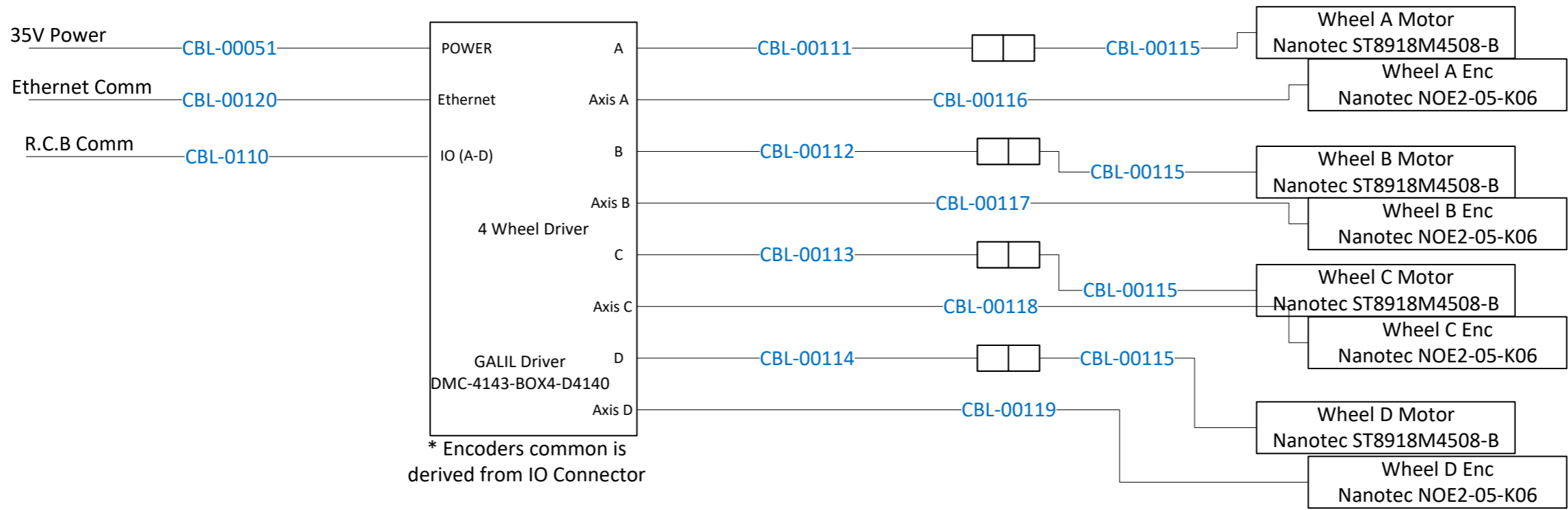

MOTOR MECHANICAL CONFIGURATION

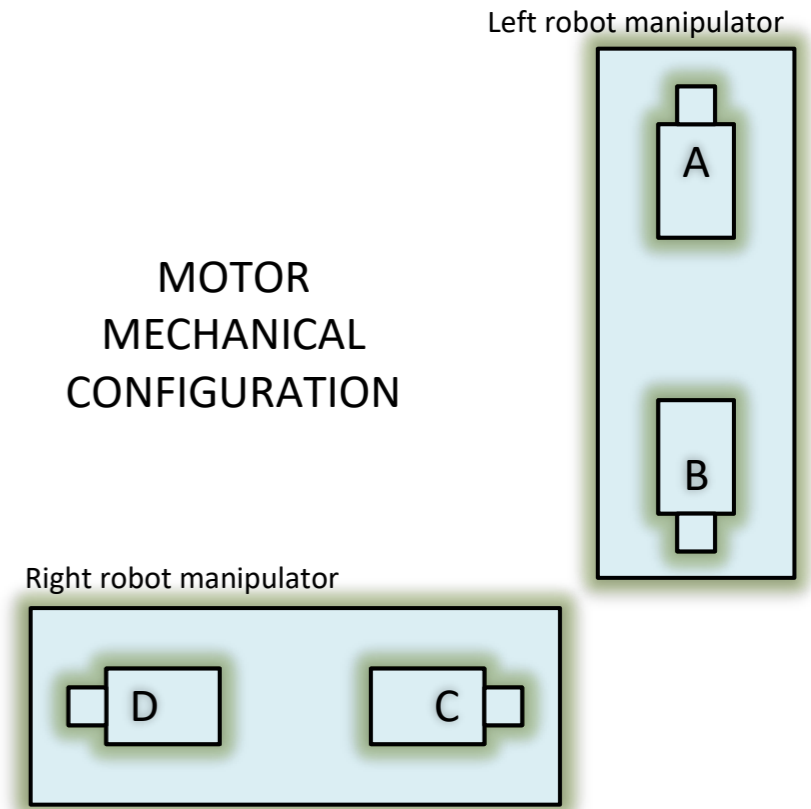

ROBOT connectivity panel

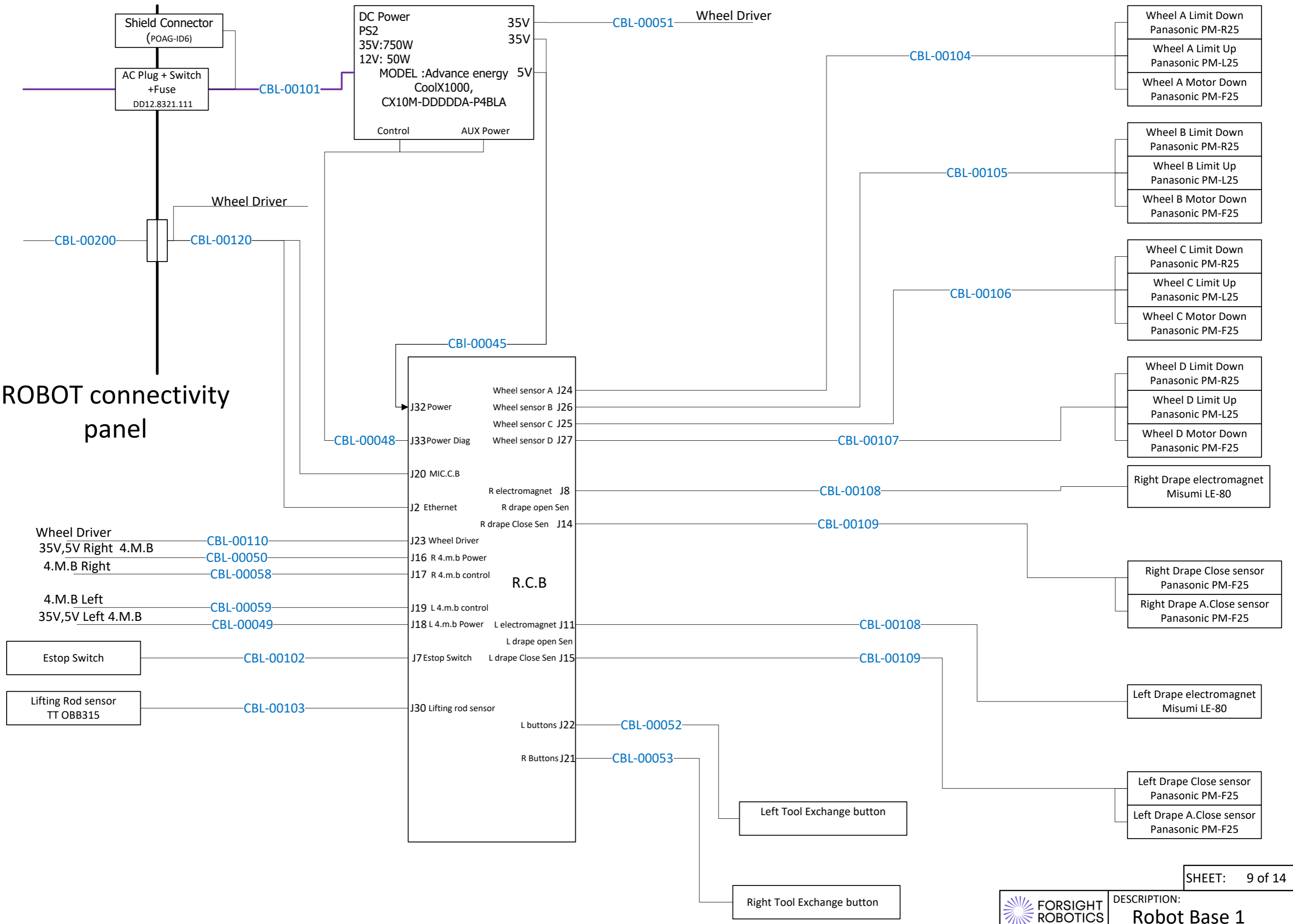

Mechanical M1 Axis

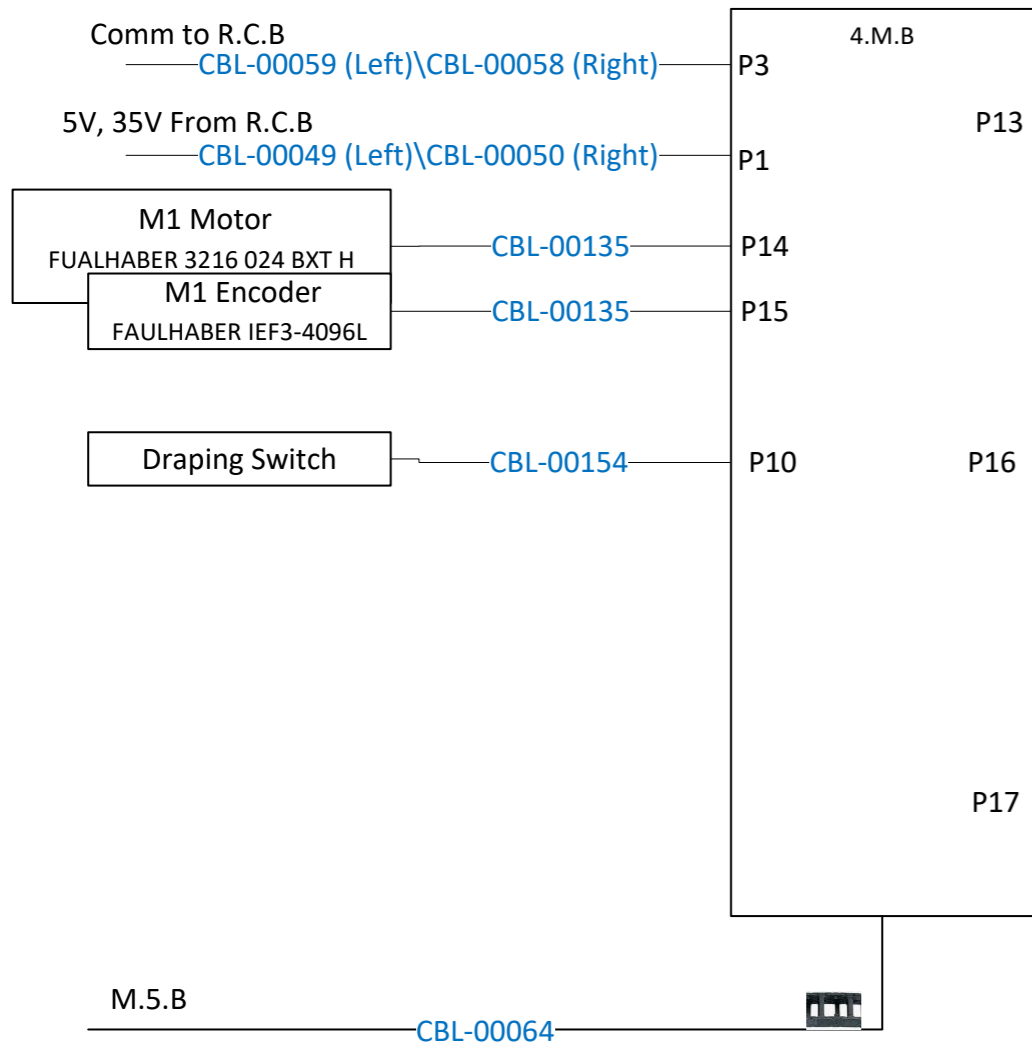

Mechanical M2 Axis

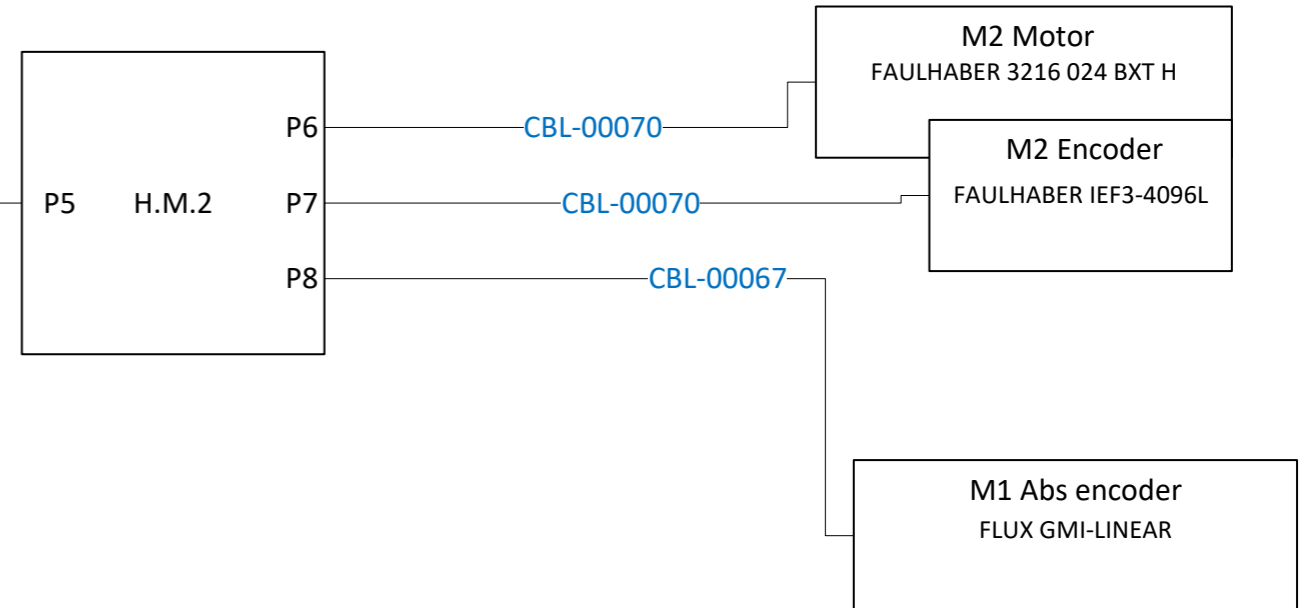

Mechanical M3 Axis

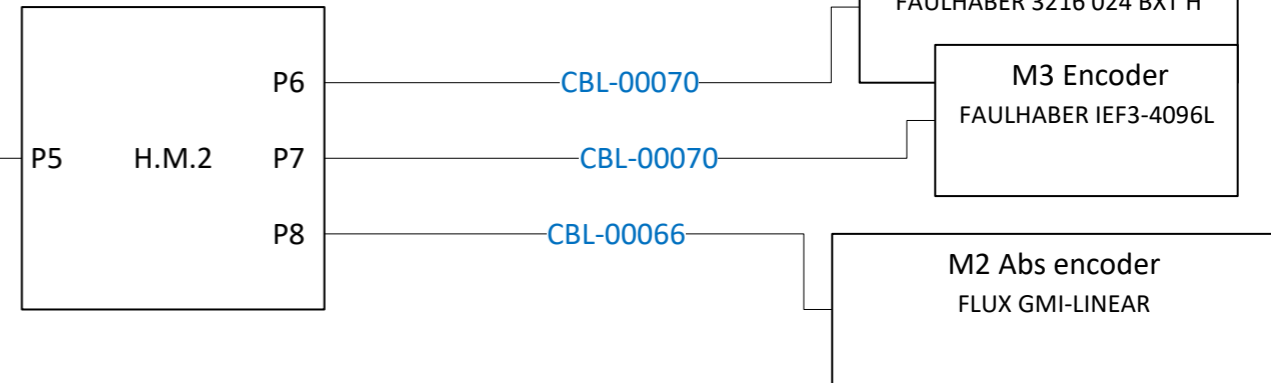

Mechanical M4 Axis

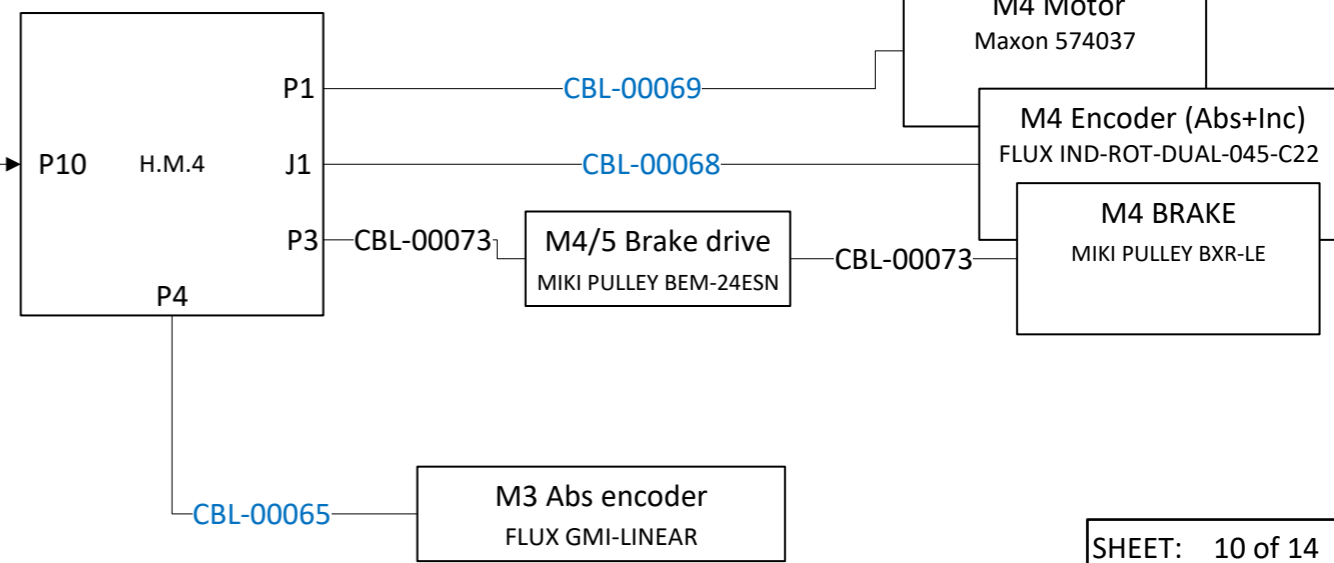

Mechanical M5 Axis

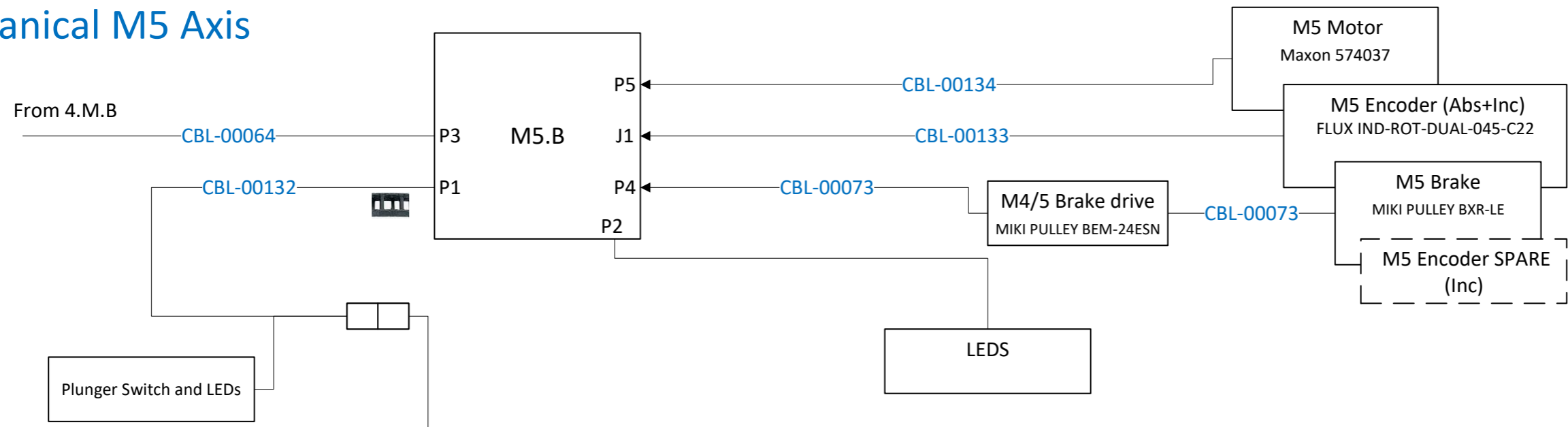

Mechanical M6/7 Axis (EEF)

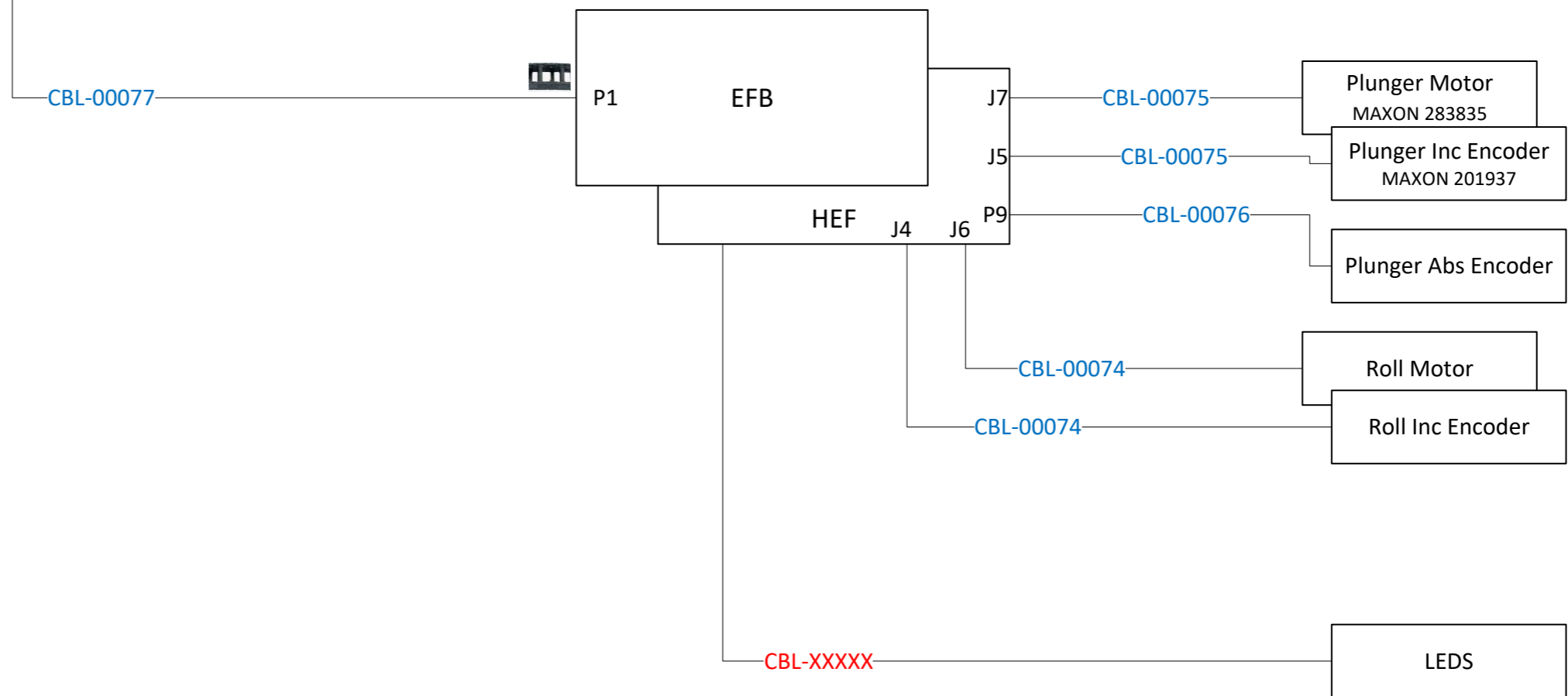

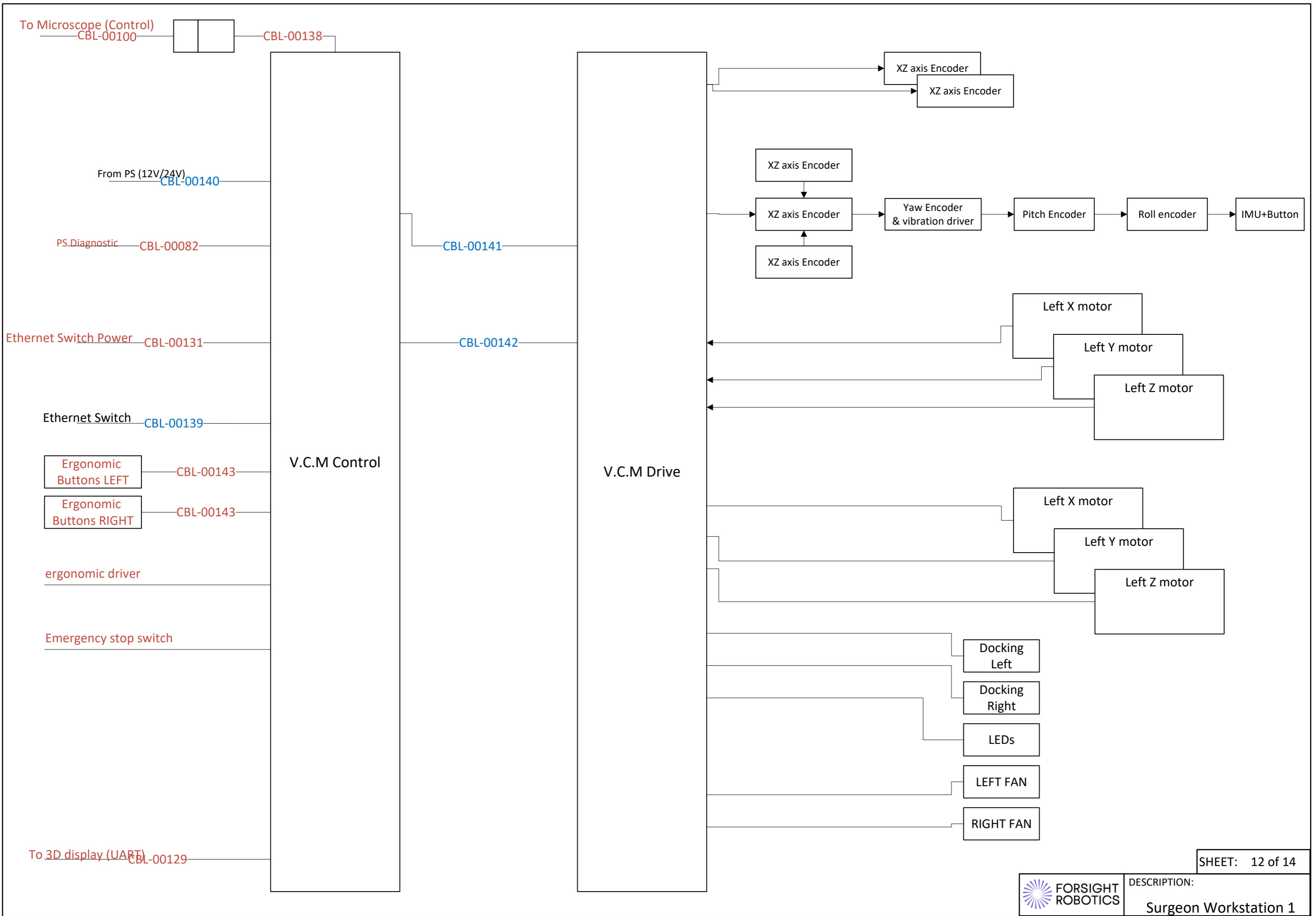

Surgeon connectivity panel

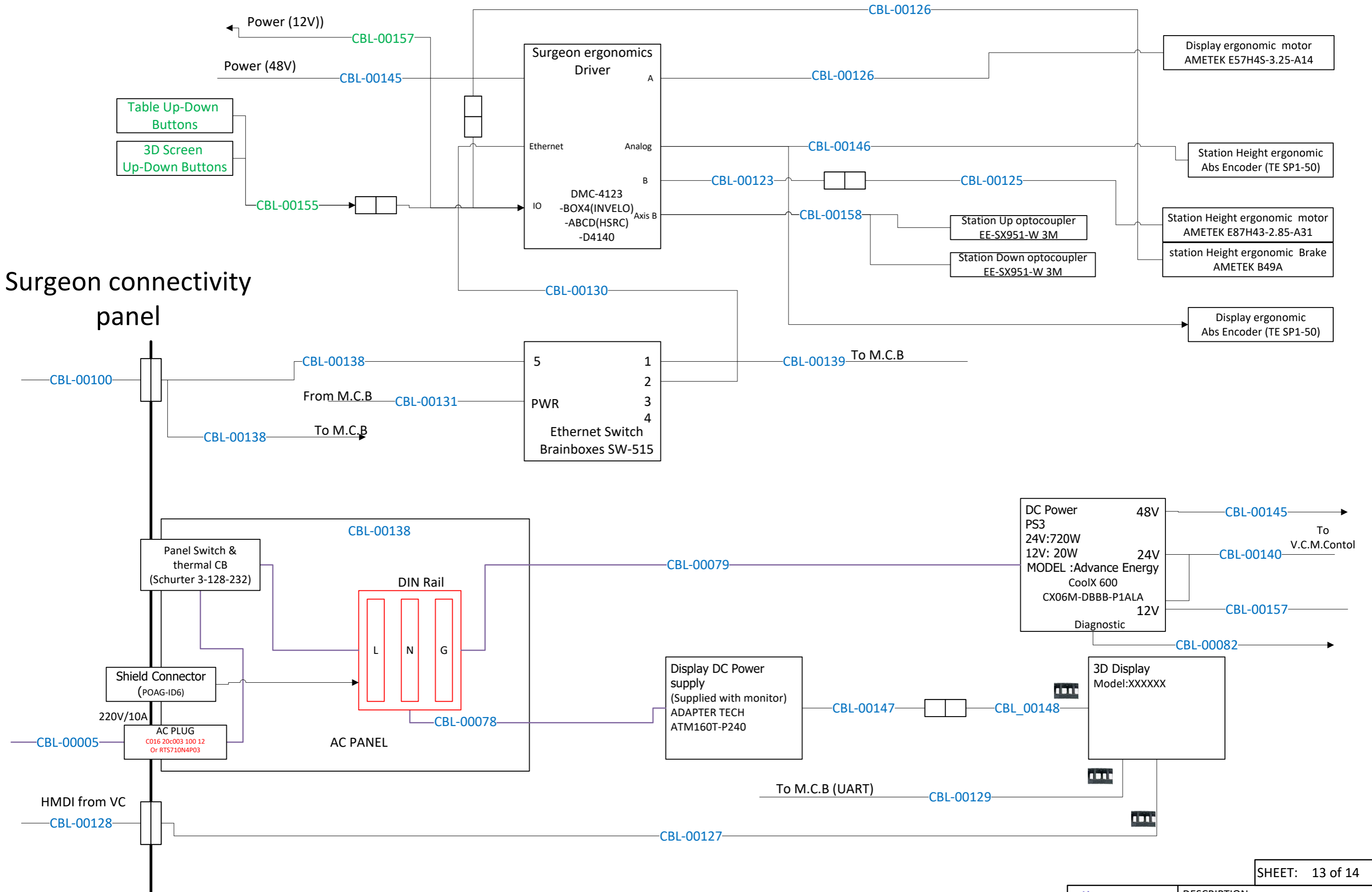



DESCRIPTION: